

RSS
by Roland

REAC

Digital Snake

S-0808 8x8 I/O UNIT

Owner's Manual

Before using this unit, carefully read the sections entitled: "USING THE UNIT SAFELY" (Owner's Manual p. 4), and "IMPORTANT NOTES" (Owner's Manual p. 6). These sections provide important information concerning the proper operation of the unit. Additionally, in order to feel assured that you have gained a good grasp of every feature provided by your new unit, Owner's Manual should be read in its entirety. The manual should be saved and kept on hand as a convenient reference.



Copyright © 2010 ROLAND CORPORATION

All rights reserved. No part of this publication may be reproduced in any form without the written permission of ROLAND CORPORATION.

For the USA

**DECLARATION OF CONFORMITY
Compliance Information Statement**

Model Name : S-0808
Type of Equipment : 8x8 I/O UNIT
Responsible Party : Roland Systems Group U.S.
Address : 425 Sequoia Drive, Suite 114, Bellingham, WA 98226
Telephone : (360)594-4282

Check the included items

The following items are included. Please make sure that all items are present. If anything is missing, please contact your dealer.

S-0808 itself



Ferrite core (two)



Bottom panel fastening screws (four)



Battery plate holder and fastening screws (eight)

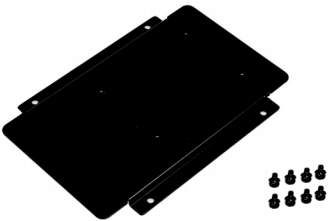

*Compatible with the P-V2 (V-Plate) made by the IDX Corporation and with the QRC-GOLD made by Anton/Bauer, Inc.

*Four screws out of eight should be used to fasten the battery plate holder to S-0808's side panel. Remaining four screws should be used to fasten battery plate (P-V2 or QRC-GOLD) to battery plate holder.

Owner's manual (this document)



REAC connector cover

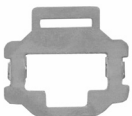

What's REAC?

REAC (Roland Ethernet Audio Communication) is a proprietary audio-signal transmission protocol from Roland that is based on Ethernet technology. It provides up to 40 channels of 24-bit, 96-kHz transmission of uncompressed audio signals. REAC devices are connected using Cat 5e (Enhanced Category 5) Ethernet cable.

What's REAC EMBEDDED POWER?

This is technology that supplies connected equipment with power while simultaneously transmitting REAC signals over the same cable. This means the equipment receiving power does not need to be connected to a power cable or a battery.

MMP (Moore Microprocessor Portfolio) refers to a patent portfolio concerned with microprocessor architecture that was developed by Technology Properties Limited (TPL). Roland has licensed this technology from the TPL Group.

* IDX and ENDURA are registered trademarks of IDX Company, Ltd.

* Anton Bauer is registered trademark of Anton/Bauser, Inc.



* Neutrik and EtherCon are registered trademarks of Neutrik, Inc.

* All product names mentioned in this document are trademarks or registered trademarks of their respective owners.



USING THE UNIT SAFELY

INSTRUCTIONS FOR THE PREVENTION OF FIRE, ELECTRIC SHOCK, OR INJURY TO PERSONS

About ⚠ WARNING and ⚠ CAUTION Notices







 WARNING	Used for instructions intended to alert the user to the risk of death or severe injury should the unit be used improperly.
 CAUTION	Used for instructions intended to alert the user to the risk of injury or material damage should the unit be used improperly. * Material damage refers to damage or other adverse effects caused with respect to the home and all its furnishings, as well to domestic animals or pets.

About the Symbols







	The ⚠ symbol alerts the user to important instructions or warnings. The specific meaning of the symbol is determined by the design contained within the triangle. In the case of the symbol at left, it is used for
	The ⊘ symbol alerts the user to items that must never be carried out (are forbidden). The specific thing that must not be done is indicated by the design contained within the circle. In the case of the symbol at left, it means that the unit must never be disassembled.
	The ● symbol alerts the user to things that must be carried out. The specific thing that must be done is indicated by the design contained within the circle. In the case of the symbol at left, it means that the power-cord plug must be unplugged from the outlet.

ALWAYS OBSERVE THE FOLLOWING

⚠ WARNING

- Do not open or perform any internal modifications on the unit. 
- Do not attempt to repair the unit, or replace parts within it (except when this manual provides specific instructions directing you to do so). Refer all servicing to your retailer, the nearest Roland Service Center, or an authorized Roland distributor, as listed on the "Information" page. 
- Never install the unit in any of the following locations. 
 - Subject to temperature extremes (e.g., direct sunlight in an enclosed vehicle, near a heating duct, on top of heat-generating equipment); or are 
 - Damp (e.g., baths, washrooms, on wet floors); or are 
 - Exposed to steam or smoke; or are
 - Subject to salt exposure; or are
 - Humid; or are
 - Exposed to rain; or are
 - Dusty or sandy; or are
 - Subject to high levels of vibration and shakiness.
- Make sure you always have the unit placed so it is level and sure to remain stable. Never place it on stands that could wobble, or on inclined surfaces. 

⚠ WARNING

- When used in combination with headphones, amps or speakers, this device is capable of producing volume levels that could cause permanent hearing loss. Do not use this device at high volumes for an extended period of time. If you should experience any loss of hearing ringing in the ears, you should immediately stop using the unit, and consult a medical professional. 
- Do not allow any objects (e.g., flammable material, coins, pins); or liquids of any kind (water, soft drinks, etc.) to penetrate the unit.  
- Immediately turn the power off, and request servicing by your retailer, the nearest Roland Service Center, or an authorized Roland distributor, as listed on the "Information" page when: 
 - If smoke or unusual odor occurs
 - Objects have fallen into, or liquid has been spilled onto the unit; or
 - The unit has been exposed to rain (or otherwise has become wet); or
 - The unit does not appear to operate normally or exhibits a marked change in performance.
- When using this device in an environment where children are present, an adult should provide supervision until the child is capable of following all the rules essential for the safe operation of the unit. 
- Protect the unit from strong impact. (Do not drop it!) 



CAUTION

- Try to prevent cords and cables from becoming entangled. Also, all cords and cables should be placed so they are out of the reach of children. 

- Never climb on top of, nor place heavy objects on the unit. 

- Disconnect all cords coming from external devices before moving the unit. 

- Keep small parts such as the following out of reach of children so that they cannot be accidentally swallowed. 
 - Removed parts :
Grounding terminal screw
 - Included items :
REAC connector covers, Ferrite core, Fastening screws for battery plate holder,
Fastening screws for bottom panel.

- Always turn the phantom power off when connecting any device other than condenser microphones that require phantom power. You risk causing damage if you mistakenly supply phantom power to dynamic microphones, audio playback devices, or other devices that don't require such power. Be sure to check the specifications of any microphone you intend to use by referring to the manual that came with it. 

(This unit's phantom power: +48 V DC,
14 mA Max)

IMPORTANT NOTES

Power Supply: Use of Batteries

- Before connecting this unit to other devices, turn off the power to all units. This will help prevent malfunctions and/or damage to speakers or other devices.

Placement

- Using the unit near power amplifiers (or other equipment containing large power transformers) may induce hum. To alleviate the problem, change the orientation of this unit; or move it farther away from the source of interference.
- This device may interfere with radio and television reception. Do not use this device in the vicinity of such receivers.
- Noise may be produced if wireless communications devices, such as cell phones, are operated in the vicinity of this unit. Such noise could occur when receiving or initiating a call, or while conversing. Should you experience such problems, you should relocate such wireless devices so they are at a greater distance from this unit, or switch them off.
- Do not expose the unit to direct sunlight, place it near devices that radiate heat, leave it inside an enclosed vehicle, or otherwise subject it to temperature extremes. Excessive heat can deform or discolor the unit.
- When moved from one location to another where the temperature and/or humidity is very different, water droplets (condensation) may form inside the unit. Damage or malfunction may result if you attempt to use the unit in this condition. Therefore, before using the unit, you must allow it to stand for several hours, until the condensation has completely evaporated.
- Depending on the material and temperature of the surface on which you place the unit, its rubber feet may discolor or mar the surface. You can place a piece of felt or cloth under the rubber feet to prevent this from happening. If you do so, please make sure that the unit will not slip or move accidentally.

Maintenance

- For everyday cleaning wipe the unit with a soft, dry cloth or one that has been slightly dampened with water. To remove stubborn dirt, use a cloth impregnated with a mild, non-abrasive detergent. Afterwards, be sure to wipe the unit thoroughly with a soft, dry cloth.
- Never use benzine, thinners, alcohol or solvents of any kind, to avoid the possibility of discoloration and/or deformation.

Repairs and Data

- Please be aware that all data contained in the unit's memory may be lost when the unit is sent for repairs. Important data should always be written down on paper (when possible). During repairs, due care is taken to avoid the loss of data. However, in certain cases (such as when circuitry related to memory itself is out of order), we regret that it may not be possible to restore the data, and Roland assumes no liability concerning such loss of data.

Additional Precautions

- Please be aware that the contents of memory can be irretrievably lost as a result of a malfunction, or the improper operation of the unit. To protect yourself against the risk of losing important data, we recommend that you periodically write down the important data you stored in the unit's memory on paper..
- Unfortunately, it may be impossible to restore the contents of data that was stored in the unit's memory once it has been lost. Roland Corporation assumes no liability concerning such loss of data.
- Use a reasonable amount of care when using the unit's switch and when using its jacks and ports. Rough handling can lead to malfunctions.
- When connecting / disconnecting all cables, grasp the connector itself—never pull on the cable. This way you will avoid causing shorts, or damage to the cable's internal elements.
- To avoid disturbing your neighbors, try to keep the unit's volume at reasonable levels. You may prefer to use headphones, so you do not need to be concerned about those around you (especially when it is late at night).
- When you need to transport the unit, package it in the box (including padding) that it came in, if possible. Otherwise, you will need to use equivalent packaging materials.
- Some connection cables contain resistors. Do not use cables that incorporate resistors for connecting to this unit. The use of such cables can cause the sound level to be extremely low, or impossible to hear. For information on cable specifications, contact the manufacturer of the cable.

Contents

Part Names and Functions	8
About the Remote Controller	10
Connecting Input and Output Devices	11
Connecting Input Devices	11
Connecting Amps and Speakers	12
Connecting REAC Devices	13
Before Making REAC Connections	13
Connecting S-0808 Units to One Another	14
Connecting to a REAC Splitter (S-4000D/S-4000-SP)	15
Connecting to a REAC Merge Unit (S-4000M)	16
Connecting to an RSS V-Mixer	17
Direct Connection to an RSS V-Mixer	17
Connecting Via an S-4000D (Configuring an M-48 System)	18
Turning the Power On and Off.....	19
Using REAC EMBEDDED POWER.....	19
Using an External Battery.....	20
About External Batteries.....	21
Setting the Input Channels	22
Making Settings Using an S-4000R.....	22
Adjusting the Preamp Gain.....	23
Switching the Gain Range (Pad)	24
Supplying Phantom Power	24
Manipulating Two Channels As a Pair (Stereo Link).....	25
Making Settings Using S-4000 RCS.....	26
Making Settings Using the RSS V-Mixer.....	26
Appendices.....	27
Troubleshooting.....	27
Main Specifications	29
Operating Time with Battery	29
Connector Information	30
Dimensions	31
Memo	32

Part Names and Functions



1. INPUT Connectors (p. 11)

Various input devices are connected to these. The inputs include a variable-gain preamp that can accept signals from -65 through +10 dBu (nominal, maximum input: +28 dBu).

INPUT 1 - 4

These are balanced female XLR connectors.

INPUT 5/6

These are balanced female XLR connectors and standard TRS connectors. When input is made to both simultaneously, the TRS input takes priority.

INPUT 7/8

These are balanced female XLR connectors and standard TRS connectors. When input is made to both simultaneously, the TRS input takes priority.

The Hi-Z switch is set to ON when receiving input from an electric guitar or other instrument with high-impedance output.

MEMO

You can adjust preamp gain and switch phantom power on and off by remote control from an S-4000R unit or a computer running the dedicated remote control software (S-4000 RCS).

NOTE

Because setting the Hi-Z switch to ON makes the system more susceptible to noise, take action to counter this, such as keeping the connector cable short.

2. REMOTE Connector (p. 22)

This is a female 9-pin D-sub connector. It is used to connect a dedicated remote controller for digital snake devices (the S-4000R) or a computer installed with dedicated remote-control software (S-4000 RCS).

3. OUTPUT Connectors (p. 12)

These are balanced male XLR connectors. Amps and powered speakers are connected here. The signal level that is output is +4 dBu (nominal, maximum output: +22 dBu).

4. REAC MODE Switch (p. 14, p. 15, p. 16, p. 17)

This sets the S-0808's operation mode. For the correct operation of the system, the mode settings of REAC devices must be made correctly. Making the wrong settings may result in incorrect audio input and output.

- M The unit functions as a REAC master device.
- S The unit functions as a REAC slave device.
- SP The unit functions as a REAC split device.

5. MUTE ALL OUTPUTS Button

This mutes (silences) the system's global audio output. When the unit is muted, you can disconnect and connect input/output or REAC cables without producing noise. When this is pressed, all output is muted within a second or two. Releasing the button cancels muting.

6. REAC Port/Indicator (p. 13)

Connect REAC device here. The indicator lights up when communication with the connected REAC device is established. It flashes during standby.

- * The S-0808 can be powered via REAC EMBEDDED POWER. When an S-4000M, S-4000D, or other device that works as power source for REAC EMBEDDED POWER is connected, the power source device automatically detects the S-0808 and starts to supply power through the REAC cable. The S-0808 is designed to operate with this supplied power. An external battery is required when no power is received from a source device providing REAC EMBEDDED POWER.

7. DC IN Port(p. 20)

This is for connecting an external battery. The unit requires an external battery when no power is received from REAC EMBEDDED POWER or when an S-4000R, dedicated remote controller is connected.

- * The unit is compatible with batteries used for broadcast video cameras (IDX or Anton/Bauer).
- * Batteries for broadcast video-cameras have a feature for displaying the remaining charge. Make sure to check the remaining charge before connecting.

8. POWER Indicator

This indicator lights up when the unit is receiving power from an external battery or a source device providing REAC EMBEDDED POWER.

Holes for the Battery Plate Holder (p. 21)

These are used when attaching an external battery. Fasten the included battery plate holder to these holes using the four dedicated screws that are also included.



About the Bottom Panel Mounting Screws

These are used when fastening S-0808 to a holder or the like. Fasten with the four included bottom panel mounting screws at the screw holes shown below.

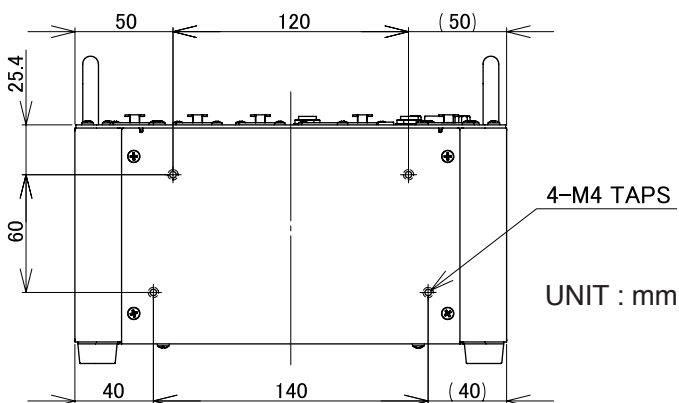

NOTE

The screws for the battery plate holder and the screws for bottom panel fastening differ in diameter and length. Both types are dedicated screws. Take care to avoid mixing them up.

About the Remote Controller

You can connect a dedicated remote controller for digital snake devices (the S-4000R) to the S-0808.

From the S-4000R, you can adjust preamp gain and switch phantom power on and off. The S-4000R supports control for up to 40 channels, but on an S-0808 system, it uses channels 1 through 16. The channels correspond to the preamps shown below.

- Channels 1 through 8: INPUT 1 through 8 on the S-0808 set to "REAC master"
- Channels 9 through 16: INPUT 1 through 8 on the S-0808 set to "REAC slave"

NOTE

The S-0808 may not boot up correctly if the power supply from a REAC EMBEDDED POWER device is started while S-4000R is connected to S-0808's REMOTE connector. Start your REAC EMBEDDED POWER device first to boot up the S-0808 and then connect an S-4000R, or supply power from external battery.

NOTE

When operating with REAC EMBEDDED POWER, the S-0808 power may turn off for a short moment if it supplies power to S-4000R and +48V phantom power devices simultaneously. However, this is not a malfunction. The power of S-0808 does not turn off if it receives power from external battery.

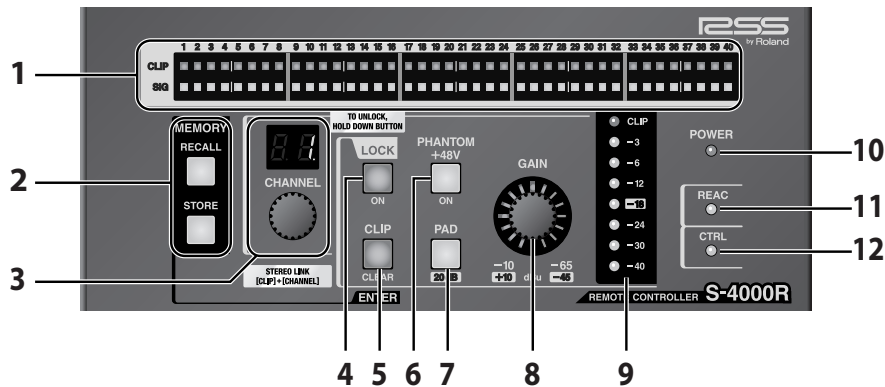

1. Signal Status Indicators

These indicate the status of signals input to the digital snake devices.

CLIP Indicators

These light up when the input signal reaches 0 dB. Pressing the [CLIP CLEAR/ENTER] button makes them go dark.

SIG Indicators

These light up when the input signal level exceeds -40 dB.

2. MEMORY Buttons

These are not used with connections to the S-0808.

3. CHANNEL Knob and Numerical Display

This selects the channel or level whose settings you want to change or the channel you want to display. The numerical display indicates the number of the currently selected channel.

4. LOCK Button

This locks operation from the S-4000R. It lights up when operation is locked. To unlock, hold down the button until its light goes dark.

5. CLIP CLEAR / ENTER Button

This flashes when any of the CLIP indicators light up. Press this when you want to make the indicators go dark.

6. PHANTOM +48V Button

This supplies +48 V phantom power to the device connected on the selected channel. It lights up when on and goes dark when off.

7. PAD Button

This applies a -20 dB pad to the input level on the selected channel.

8. GAIN Knob

This adjusts the input gain on the selected channel.

9. Input Level Meter

This displays the input level on the selected channel.

10. POWER Indicator

This lights up when power is supplied to the S-4000R via an RS-232C cable.

11. REAC Indicator

This lights up when the connected S-0808 begins REAC communication.

12. CTRL Indicator

This lights up when communication is established between the S-4000R and the S-0808.

Connecting Input and Output Devices

Feedback can be produced depending on the location of microphones relative to speakers. This can be remedied by:

1. Changing the orientation of the microphone(s).
2. Relocating microphone(s) at a greater distance from speakers.
3. Lowering volume levels.

- * To prevent malfunctions and/or damages to speakers or other devices, always turn down the volume, and turn off the power on all devices before making any connections.
- * This unit is equipped with balanced (XLR/TRS) type jacks. Wiring diagrams for these jacks are shown on "Connector Information" (p. 30). Make connection after first checking the wiring diagram of other equipment you intend to connect.

Connecting Input Devices

Connect input devices to INPUT 1 through 8. You can connect male XLR connectors to INPUT 1 through 8. Standard TRS connectors are connected to INPUT 5 through 8.

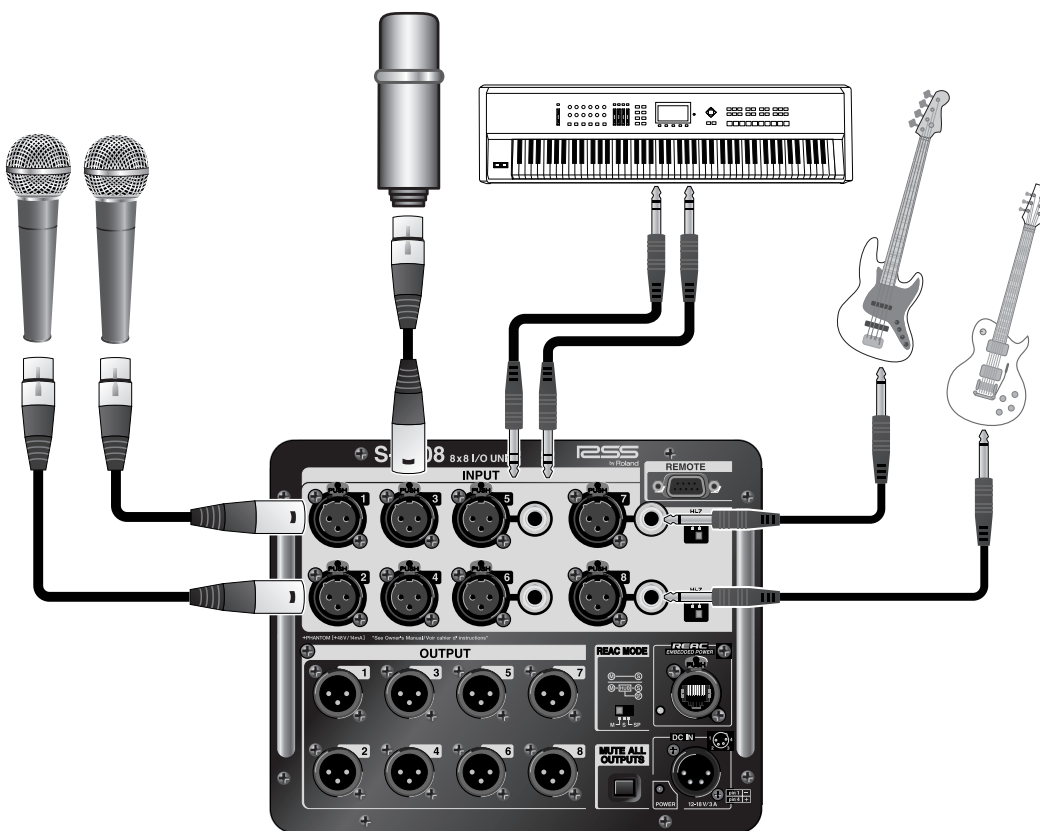

- * When XLR and TRS connections are both made simultaneously to one of the connectors at INPUT 5 through 8, the TRS input takes priority.
- * When connection cables with resistor are used, the volume level of equipment connected to the inputs (INPUT 1 through 8) may be low. If this happens, use connection cables that do not contain resistors.

MEMO

Connect electric guitars or other instruments with high-impedance output to INPUT 7 or 8. At this time, set the Hi-Z switch next to the INPUT connector to ON. Setting the Hi-Z switch to ON makes INPUT 7/8 unbalanced.

MEMO

You can supply +48 V phantom power from the XLR connectors at INPUT 1 through 8. When a condenser microphone or the like is connected and supplying phantom power is required, switch it on by remote control. Refer to "Setting the Input Channel" (p. 22).

MEMO

Preamp gain and phantom power on/off settings made by remote control remain in memory after the power to the S-0808 is switched off. You can ensure that the settings are stored in memory by locking the remote control before switching off the power. If you're using the S-4000R, press the [LOCK] button to make it light up, wait several seconds, then power off the S-0808.

Connecting Amps and Speakers

Connect amps and powered speakers to OUTPUT 1 through 8. OUTPUT 1 through 8 on the S-0808 are male connectors. Use female XLR connectors to make the connections.

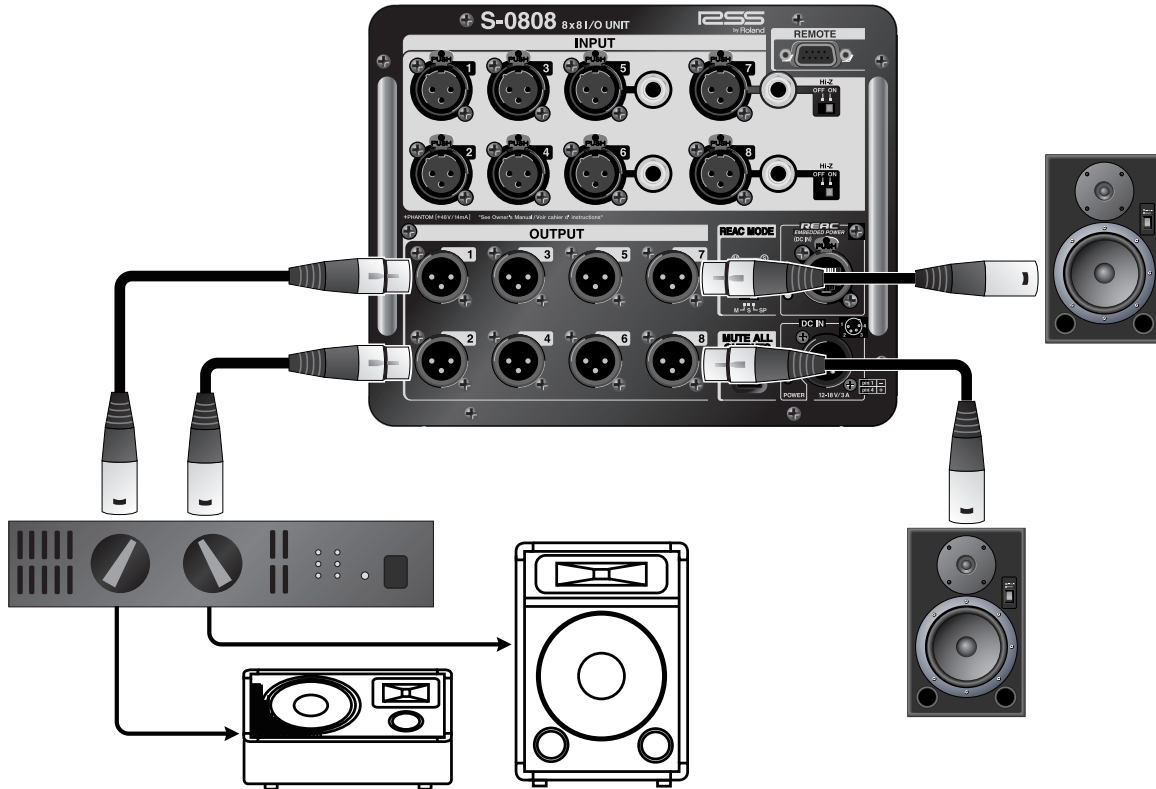

MEMO

The signal level that is output is +4 dBu (nominal, maximum output: +22 dBu).

MEMO

If the input to the connected amps or powered speakers is too high and the audio output is distorted, adjust the gain using the input attenuator for the amp. Adjusting by lowering the preamp gain on the S-0808 may result in a poor signal-to-noise ratio.

Connecting REAC Devices

Before Making REAC Connections

Cables for REAC Connections

With RSS Digital Snake and V-Mixing Systems, digital transmission of audio signals is performed by means of REAC (Roland Ethernet Audio Communication). Compared to analog transmission, this system is extremely resistant to external noise, but in very rare instances, noise can occur. Selection of the wrong cable and incorrect cable handling can cause noise. Observe the following points when using cables.

- Ensure that the cables used for connections conform to the Cat 5e (Enhanced Category 5) standard.
- No single cable should be longer than 100 meters.
- Do not use cables with cut or torn covering.
- Do not step on cables or subject them to undue stress.
- Do not wind cables too tightly or sharply bend them.

To maintain transmission quality, use of the following optional REAC cables is recommended.

- 100-meter cables: SC-W100S (cable only) or W100S-R (with reel)
- 20-meter cables: SC-W20F

REAC Connector Cover

When using an ordinary available Ethernet cable (as opposed to optional cables) to connect a REAC device, fit the included REAC connector covers onto the REAC ports. Electromagnetic noise may be a problem if these are left unattached.

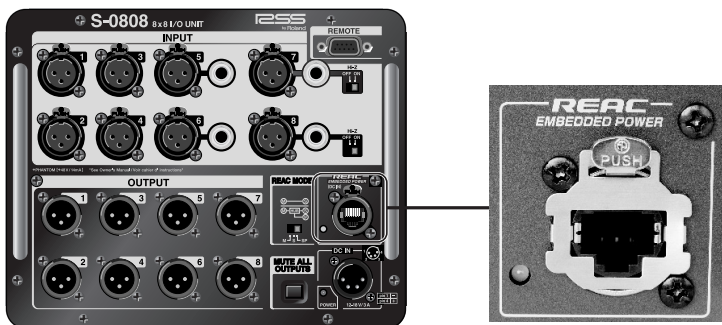

- * Attaching a REAC connector cover is not necessary when you're using an optional REAC cable (described above). When using an ordinary available Ethernet cable, be sure to use a cable that conforms to the Cat 5e (Enhanced Category 5) standard.

About Ferrite Cores

The S-0808 comes with two ferrite cores. Attach one ferrite core to the REAC cable connected to the S-0808. Clamp the ferrite core onto the cable at a location near the plug at the end of the cable, pressing down on the ferrite core until it clicks closed.

Attach another ferrite core to the power cable from the external battery.

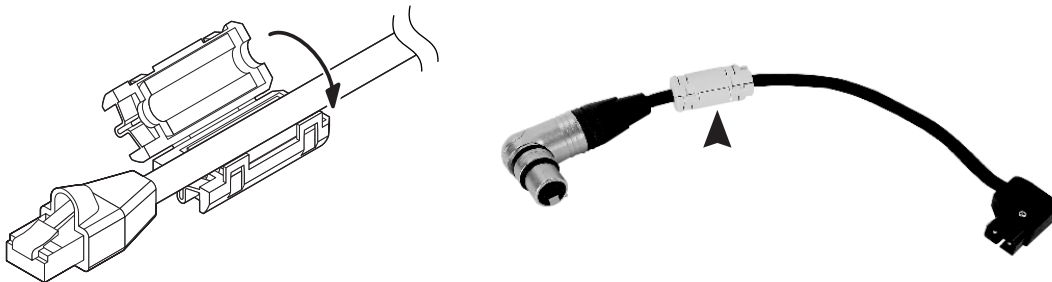

- * When attaching a ferrite core, be careful to avoid pinching your fingers.
- * When connecting a REAC device, use a cable that has a ferrite core attached to it.

Connecting S-0808 Units to One Another

You can configure a simple digital snake system having 8-channel inputs and 8-channel outputs by installing one S-0808 at the stage and another one at the mixing desk (front of house [FOH]).

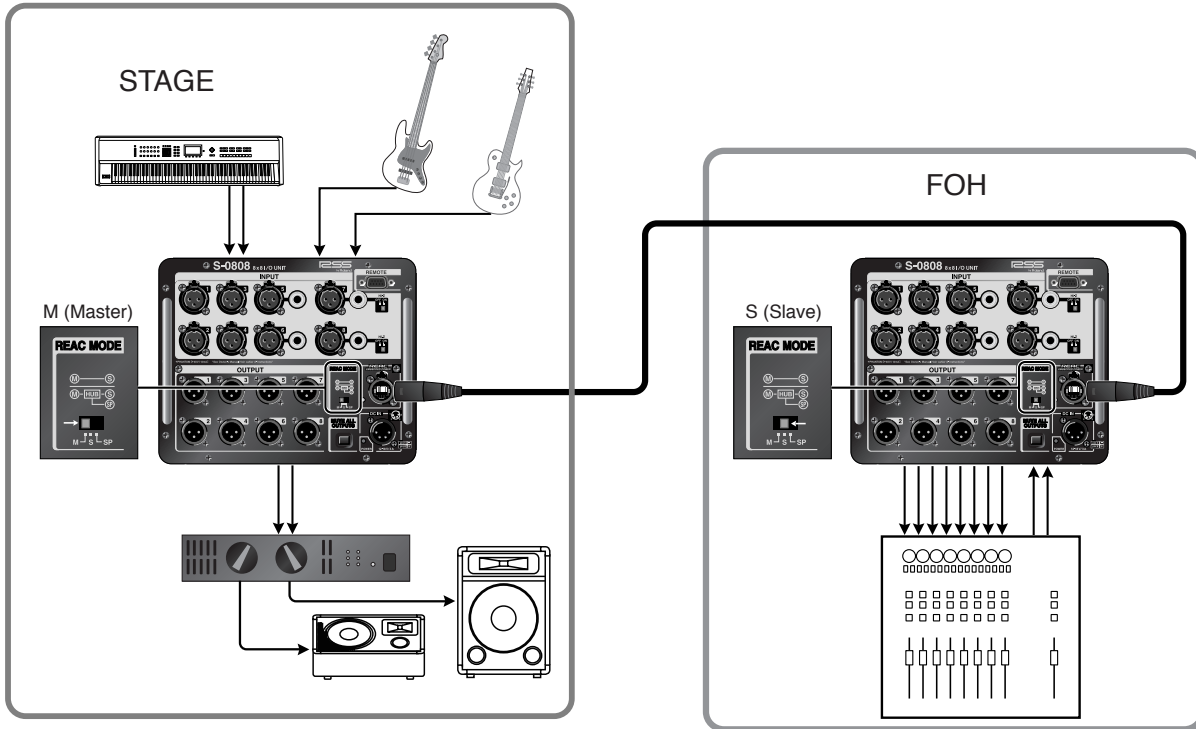

* Set the operation mode of the S-0808 at the stage to M (master) and the mode of the S-0808 at FOH to S (slave). The signals from INPUT 1 through 8 on the master unit are output to OUTPUT 1 through 8 on the slave unit, and the signals from INPUT 1 through 8 on the slave unit are output to OUTPUT 1 through 8 on the master unit.

NOTE

Make the settings for the REAC mode only when the S-0808 units are powered off.

NOTE

When connecting two S-0808 units directly using a REAC cable, attach external batteries to both S-0808 units and power them via their DC IN ports. For more information about external batteries, refer to "Using an External Battery" (p. 20).

NOTE

The output level of OUTPUT 1 through 8 on the S-0808 is fixed at +4 dBu (nominal, maximum: +22 dBu). When connecting the unit to a mixer at the FOH, make the connection to an input connector capable of a maximum +22 dBu signal.

Connecting to a REAC Splitter (S-4000D/S-4000-SP)

Connecting an S-4000D or S-4000-SP or an ordinary available Ethernet switching hub lets you split the input signals of the REAC master device. When you want to output audio not to speakers but to recording or broadcast equipment, make the connections as shown below.

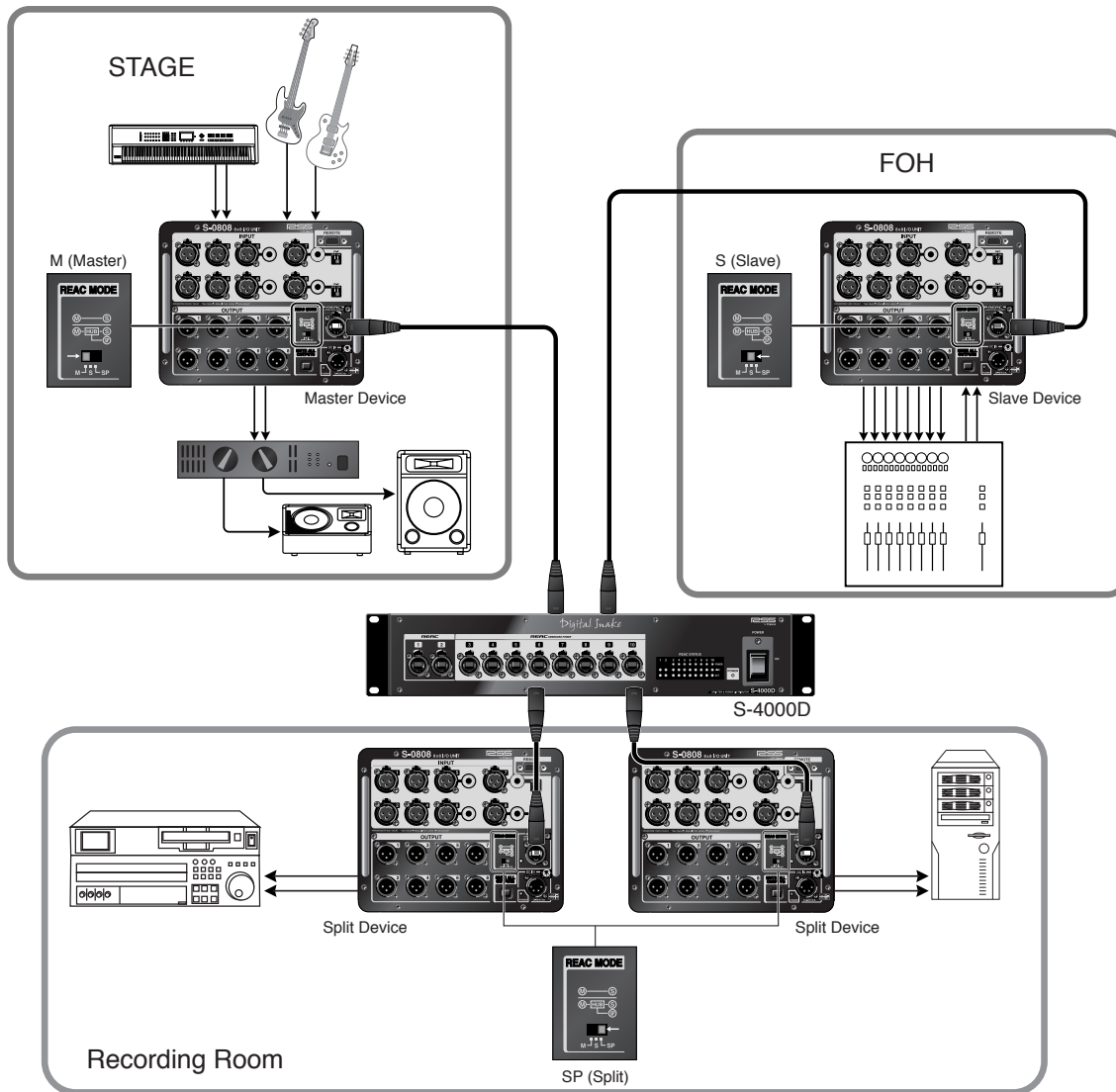

* Set the operation mode of the S-0808 unit at the recording equipment to SP (split). Set the unit at the stage to M (master) and the unit at FOH to S (slave), in the same way as when connecting two S-0808 units to one another.

NOTE

Make the settings for the REAC mode only when the S-0808 units are powered off.

NOTE

When power is provided by an S-4000M, S-4000D, or other source device providing REAC EMBEDDED POWER, no external batteries are required. However, when you're using an S-4000-SP, an ordinary available Ethernet switching hub, or other equipment that does not support REAC EMBEDDED POWER, external batteries must be installed on all the S-0808 units to power them via their DC IN ports. For more information about external batteries, refer to "Using an External Battery" (p. 20).

NOTE

The REAC splitter set to the split mode operates only to receive signals from the REAC master device. Signals input to the REAC splitter cannot be sent to other REAC devices.

MEMO

The signals output by the REAC splitter are the same as the signals output from the OUTPUT connectors of the REAC slave device. The connector numbers are also the same.

Connecting to a REAC Merge Unit (S-4000M)

The S-4000M is a REAC merge unit that can collectively configure multiple REAC slave devices. You can configure a larger-scaled system by connecting multiple S-0808 units set to be REAC slave devices to a REAC master device via an S-4000M.

* When the connection is made via an S-4000M, the REAC master device (in the figure below, this is the S-4000H) sees the multiple S-0808 units as a single REAC slave device.

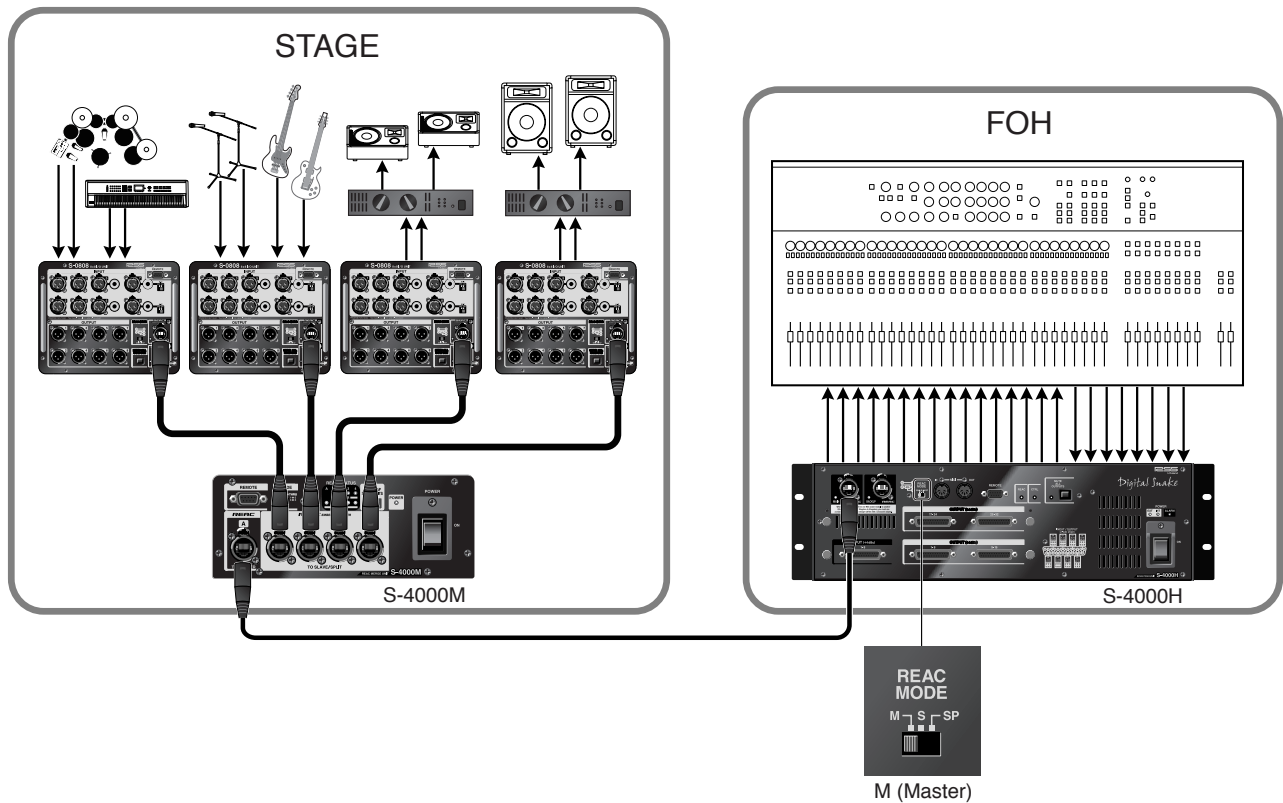

* Set the operation mode of all S-0808 units connected to the S-4000M to S (slave).

NOTE

Make the settings for the REAC mode only when the S-0808 units are powered off.

NOTE

The S-0808 units are powered by the S-4000M. No external batteries are required when these connections are made. Connect S-4000R or computer with dedicated remote control software (S-4000 RCS) to the REMOTE connectors of S-4000M or S-4000H for remote control of input preamps on S-0808 units.

Connecting to an RSS V-Mixer

You can connect RSS V-Mixer and use S-0808 as the stage unit in a V-Mixing System.

Direct Connection to an RSS V-Mixer

As with other digital snake devices, you can make a direct connection for use as V-Mixer's stage unit. Make the connection to REAC port A or B on the V-Mixer.

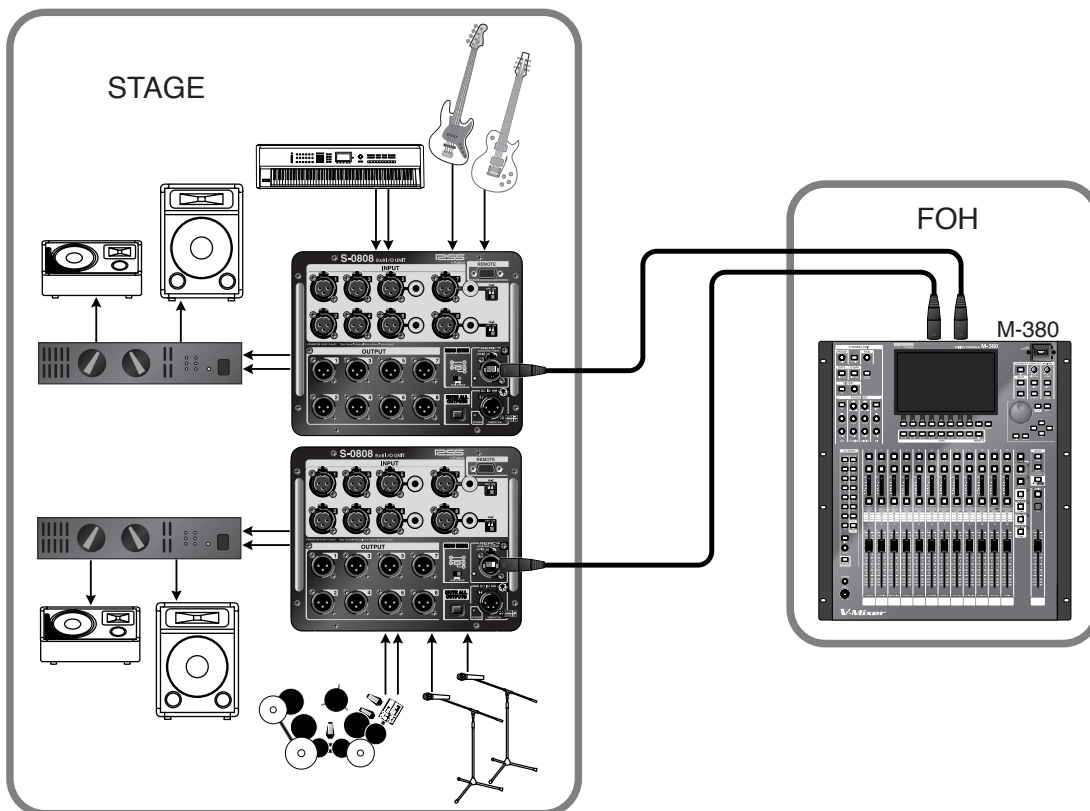

- * Set the operation mode of all S-0808 units connected to the V-Mixer to S (slave).
- * Depending on the version of the RSS V-Mixer, the S-0808 units might be recognized as S-4000S units (each configured with modules for 8 inputs + 8 outputs).

NOTE

Make the settings for the REAC mode only when the S-0808 units are powered off.

NOTE

The RSS V-Mixer does not supply REAC EMBEDDED POWER. When making these connections, attach external batteries to all S-0808 units and power them via their DC IN ports. For more information about external batteries, refer to "Using an External Battery" (p. 20). Note, however, that when the S-0808 units are connected to the RSS V-Mixer via an S-4000M, the S-0808 units are powered by the S-4000M and no external batteries are required. For information about how to make the connection to the RSS V-Mixer via an S-4000M, refer to the owner's manual of the S-4000M.

Connecting Via an S-4000D (Configuring an M-48 System)

When setting up a system that includes the M-48 live personal mixer, you connect the V-Mixer via an S-4000M and an S-4000D. Connect the S-0808 units to the S-4000M and the M-48 units to the S-4000D.

* For information about the modes and other settings of the S-4000D and the S-4000M, refer to the owner's manuals of these devices.

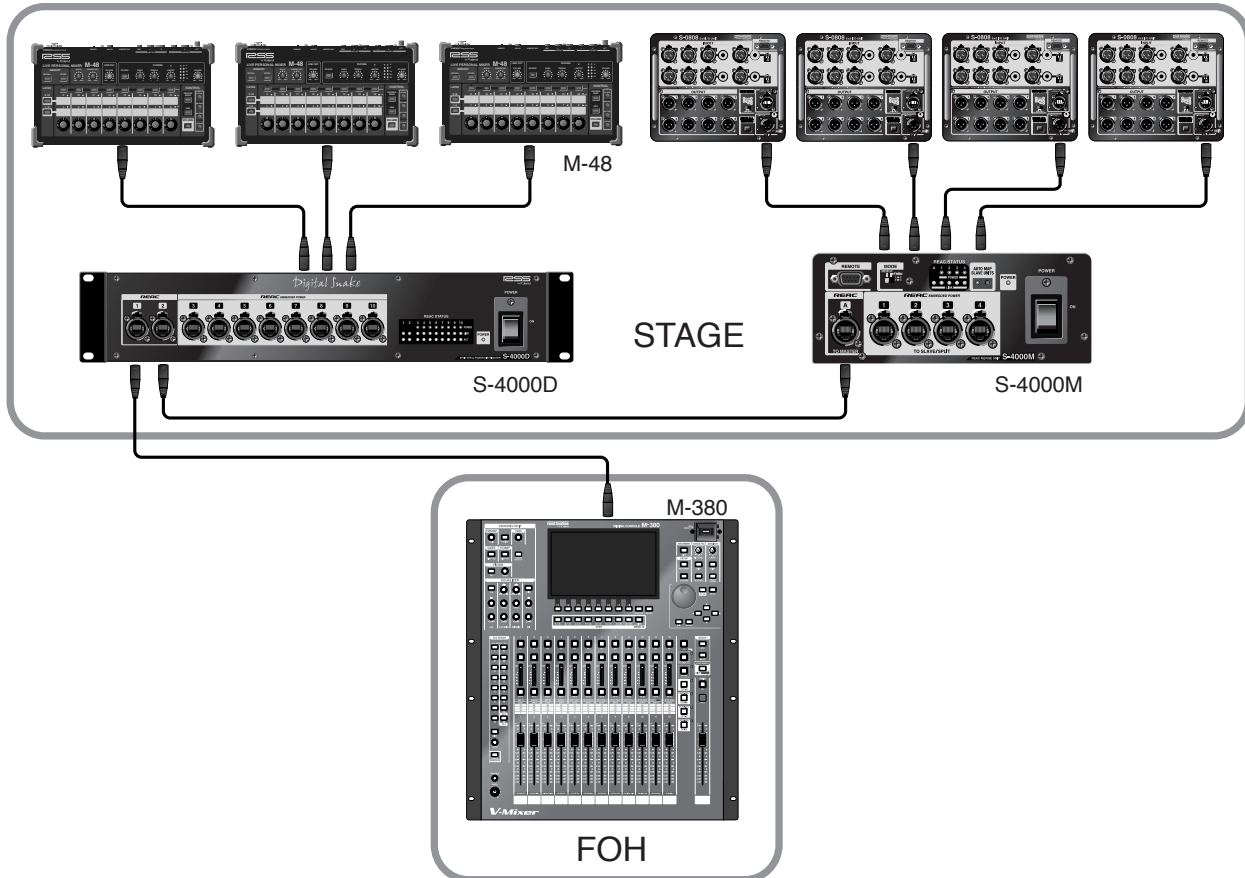

* Set the operation mode of all S-0808 units connected to the S-4000M to S (slave).

NOTE

Make the settings for the REAC mode only when the S-0808 units are powered off.

NOTE

The S-0808 units are powered by the S-4000M. No external batteries are required when these connections are made.

Turning the Power On and Off

The S-0808 is compatible with the following two types of power sources.

- **REAC EMBEDDED POWER** When the unit is connected to an S-4000M, S-4000D, or other source device of REAC EMBEDDED POWER, it operates with power supplied via the REAC cable.
 - **External battery** When the unit is not connected to a source device providing REAC EMBEDDED POWER, the unit must be powered by an external battery. Use a battery for broadcast video cameras as the external battery.
- * Once the connections have been completed, turn on power to your various devices in the order specified. By turning on devices in the wrong order, you risk causing malfunction and/or damage to speakers and other devices.
- * Always make sure to have the volume level turned down before switching on power. Even with the volume all the way down, you may still hear some sound when the power is switched on, but this is normal, and does not indicate a malfunction.

Using REAC EMBEDDED POWER

Connecting device providing REAC EMBEDDED POWER like the S-4000M or S-4000D enables power to be supplied via the REAC cable.

- * Power is supplied from certain REAC ports of device providing REAC EMBEDDED POWER. Before making the connections, check which ports can supply power. For information on which ports can supply power, refer to the owner's manuals for the respective devices.

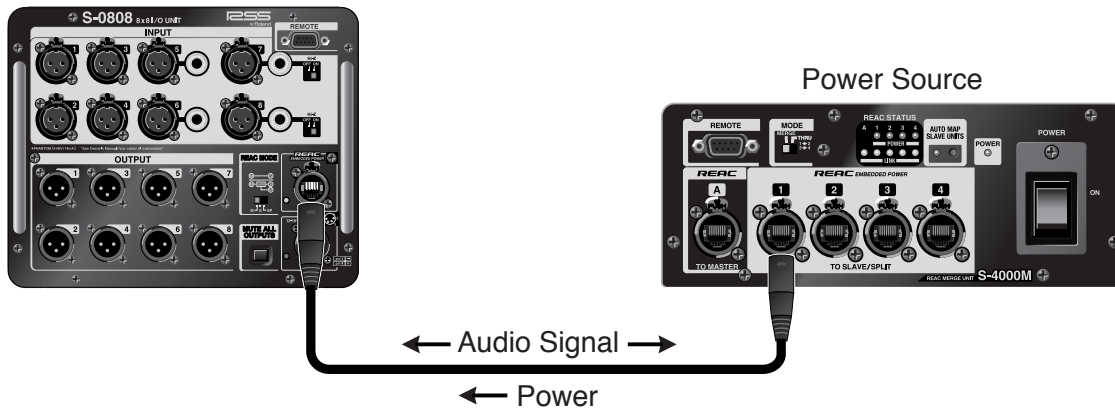

Turning the Power On

1. Using a REAC cable, make the connection with the power source.

Using a REAC cable, connect the device providing REAC EMBEDDED POWER like the S-4000M or S-4000D.

- * Before making the connections, switch off the power on all the devices.

2. Switch on the power on the source device.

Switch on the of source device. The POWER indicator on the S-0808 lights up, and then the REAC indicator flashes.

NOTE

If any amps or speakers are connected to the REAC devices, then to prevent malfunction or damage to the speakers or other devices, always turn down the volume, and turn off the power on all devices before making any connections.

NOTE

The S-0808 may not boot up correctly if the power supply from REAC EMBEDDED POWER source device is started while S-4000R is connected to S-0808's REMOTE connector. Start power from your REAC EMBEDDED POWER source device first to boot up S-0808 and then connect S-4000R, or supply power from external battery.

Turning the Power Off

Switch off the power on the REAC EMBEDDED POWER source device. After powering down all devices, detach the REAC cable.

Using an External Battery

To supply power from an external battery, first install the holder included with the S-0808 on the battery plate. Connecting the power cable from the external battery to the DC IN port on the S-0808 starts the supply of power.

- * The included holder is compatible with the P-V2 (V-Plate) from IDX Company, Ltd. and the QRC Gold from Anton/Bauer, Inc.
- * Batteries for broadcast video-cameras have a feature to display the remaining charge. Check the remaining charge before connecting.

NOTE

The external battery, battery plate, and power cable are not included. Purchase these separately. Attach the included ferrite core to the power cable from the external battery.

NOTE

To prevent depletion of the battery, disconnect the power cable from the DC IN port when the S-0808 is not in use.

NOTE

No external battery is necessary when the S-0808 is receiving power from a source device providing REAC EMBEDDED POWER. However, when an S-4000R is connected to the S-0808 and +48 V phantom power is being supplied to input devices, supply power from an external battery connected to its DC IN port.



Turning the Power On

1. Install the battery plate on the included holder.

Using four of the included fastening screws for the battery plate holder, attach the P-V2 (V-Plate) or QRC Gold plate to the included holder.

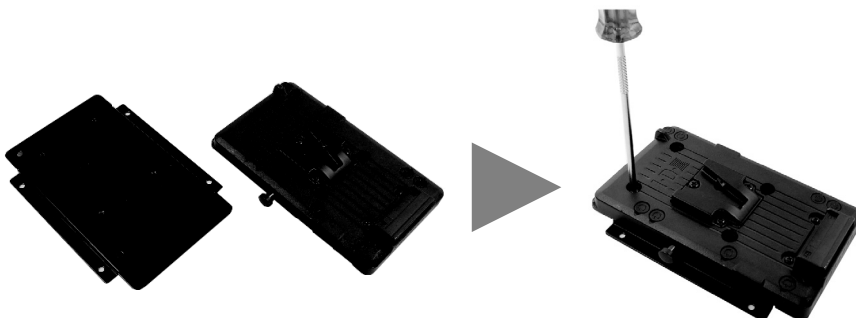

NOTE

Eight fastening screws for the battery plate holder are included. They differ in diameter and length from the four included fastening screws for the bottom panel. Both types are dedicated screws. Take care to avoid mixing them up.

2. Fasten the holder and battery plate assembled in step 1.

Using four included screws, fasten the battery plate and holder assembly to the side panel of the S-0808.

* Be careful not to overtighten, because doing so may damage the S-0808.

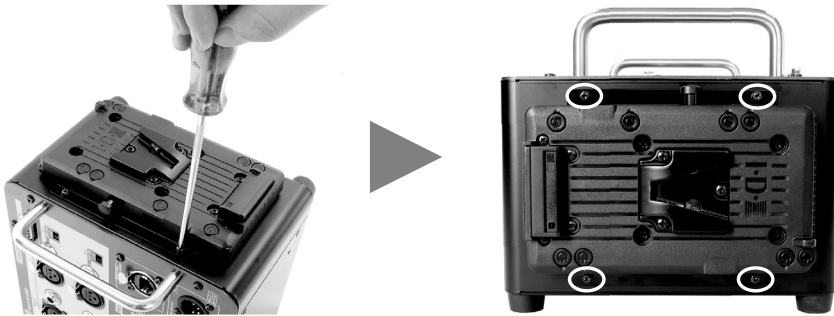

3. Install the external battery.

Install a compatible external battery on the battery plate.



4. Start supplying power from the external battery.

Connect the power cable to the DC IN port on the S-0808. The supply of power starts and the S-0808 is powered up. The POWER indicator lights up when the power comes on.



Turning the Power Off

Disconnecting the power cable from the S-0808's DC IN port cuts off the power to the S-0808.

About External Batteries

External batteries providing an output voltage between 12 V and 18 V DC are supported. Use a product within this range. The operating time when using a fully charged ENDURA-10 (E-10) from IDX Company, Ltd. is approximately 4.5 hours.

- * This is the operating time when +48 V phantom power is supplied to all INPUT channels.
- * Operating times may vary depending on ambient temperature, the current consumption of the device receiving +48 V phantom power, and other usage conditions.
- * Batteries for broadcast video-cameras have a feature to display the remaining charge. Check the remaining charge before connecting. It is possible to check the remaining charge while supply power to S-0808. It is recommended to check remaining charge periodically.

Setting the Input Channels

You can connect an S-4000R or a computer to the REMOTE connector on the S-0808 and make various settings for the input channels. When a REAC connection to an RSS V-Mixer has been made, you can make settings in the same way from the V-Mixer's panel as well.

NOTE

The S-0808 may not boot up correctly if the power supply from a REAC EMBEDDED POWER device is started while S-4000R is connected to S-0808's REMOTE connector. Start your REAC EMBEDDED POWER device first to boot up the S-0808 and then connect an S-4000R, or supply power from external battery.

NOTE

When operating with REAC EMBEDDED POWER, the S-0808 power may turn off for a short moment if it supplies power to S-4000R and +48V phantom power devices simultaneously. To avoid this problem, use an external battery as the power supply.

NOTE

The memory feature of the S-4000R does not function when the S-4000R is connected to the S-0808.

Making Settings Using an S-4000R

The S-4000R is a dedicated remote controller for digital snake devices. For information on the names and functions of S-4000R features, refer to "About the Remote Controller" (p. 10).

You connect the S-4000R to the REMOTE connector on the S-0808 using the RS-232C cable.



Unlocking

To change various settings on the digital snake device, unlock the S-4000R. When the [LOCK] button is illuminated, operation is locked and no setting operations can be carried out. Hold down the [LOCK] button for few seconds, and make sure its light goes dark.



MEMO

To keep settings from being changed by inadvertent operation, it's a good idea to engage the lock when you have finished making the input-channel settings. Press the [LOCK] button to engage the lock and make the button light up.

Adjusting the Preamp Gain

With digital snake devices, you can adjust the preamp gain in the stage unit.

1. Select the channel.

Turn the [CHANNEL] knob to select the number of the channel whose settings you want to change.

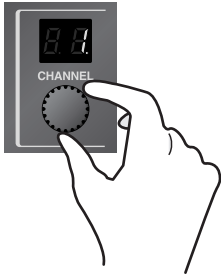

2. Input the audio.

From the source devices, input the audio on the selected channel.

3. Adjust to a suitable level.

Turn the [GAIN] knob to adjust to a suitable level. The indicators around the knob indicate the gain level. The input level on the select channel is displayed by the input level meter.

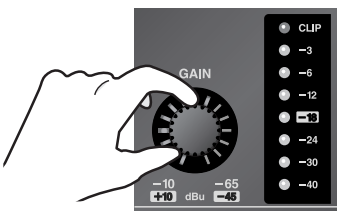

4. Select another channel.

Turn the [CHANNEL] knob to select another channel, then repeat steps 2 and 3.

TIP

If the input level reaches 0 dB, the [CLIP] area of the input level meter and the [CLIP] area of the signal status indicator light up. If this happens, the audio may be distorted. To transmit high-quality audio, adjust the preamp gain so that the peak level on the input level meter fluctuates between -18 and -3 dB.

MEMO

To make the illuminated [CLIP] indicators go dark, press the [CLIP CLEAR/ENTER] button.

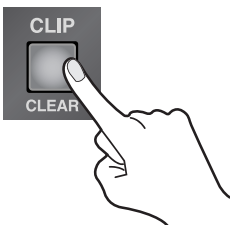

Switching the Gain Range (Pad)

You can switch the pad on and off to change the variable range of the preamp gain for individual channels. When the pad is on, a pad of 20 dB is applied to the input level on the channel. If CLIP lights up even when the [GAIN] knob has been turned all the way counterclockwise to minimize the preamp gain, engage the pad on the channel.

1. Select the channel.

Turn the [CHANNEL] knob to select the number of the channel whose settings you want to change.

2. Engage the pad.

Press the [PAD] button. The button lights up and the input level on the channel is lowered.

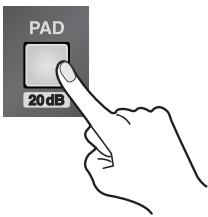

If you want to engage pads on other channels as well, repeat the steps just described.

* To suppress noise when the pad is switched on or off, the audio on the selected channel is momentarily muted.

Supplying Phantom Power

You can supply phantom power from the S-0808 when a condenser microphone or other device requiring +48 V of power is connected.

NOTE

Be sure to switch off phantom power when no device requiring +48 V phantom power is connected. Inadvertently supplying phantom power to a dynamic microphone, audio playback device, or other equipment may cause malfunction. Carefully check the documentation included with the microphone or other equipment you're using to determine its specifications.

(Phantom power supplied by the S-0808: +48 V DC at 14 mA maximum on each channel)

1. Select the channel.

Turn the [CHANNEL] knob to select the number of the channel on which you want supply phantom power.

2. Supply phantom power.

Press the [PHANTOM/+48V] button. The button lights up and +48 V phantom power is supplied on the selected channel.

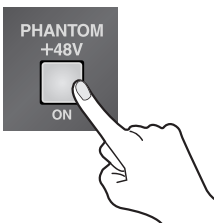

If you want to supply phantom power on other channels as well, repeat the steps just described.

* To suppress noise when phantom power is switched on or off, the audio on the selected channel is temporarily muted.

Manipulating Two Channels As a Pair (Stereo Link)

Using the Stereo Link feature lets you simultaneously manipulate two adjacent channels, one odd-numbered and one even (1 and 2, 3 and 4, 5 and 6, or 7 and 8). You use this when you're inputting a stereo sound source to the S-0808. When Stereo Link is on, the gain, pad, and other settings made on the odd-numbered channel are automatically copied to the even-numbered channel.

Switching On Stereo Link

1. Select the channel.

Turn the [CHANNEL] knob to select one of the channels you want to link. If you want to link channels 3 and 4, choose [03] or [04].

2. Link the odd-numbered and even-numbered channels.

Hold down the [CLIP CLEAR/ENTER] button and turn the [CHANNEL] knob clockwise. This switches on Stereo Link.

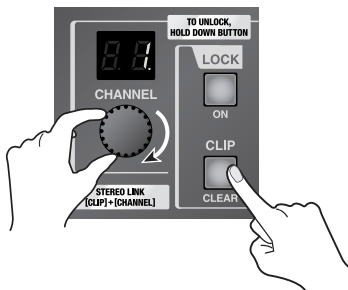

3. Make sure the link is in effect.

When you release the [CLIP CLEAR/ENTER] button, two periods (".") appear in the channel number shown on the numerical display.

When ch 7 and 8
are linked



Switching Off Stereo Link

1. Select the channel.

Turn the [CHANNEL] knob to select one of the channels you want to unlink.

2. End the link.

Hold down the [CLIP CLEAR/ENTER] button and turn the [CHANNEL] knob counterclockwise. This switches off Stereo Link.

3. Make sure that the link has ended.

When you release the [CLIP CLEAR/ENTER] button, the two periods that are displayed disappear from the numerical display.

MEMO

Even when Stereo Link is on, you can still switch +48 V phantom power on and off independently for individual channels.

NOTE

Switching off Stereo Link does not make the values for gain, pad, and other settings go back to what they were before Stereo Link was switched on. The values made while linked remain in effect.

Making Settings Using S-4000 RCS

You can also make settings on the input channels using dedicated remote control software for digital snake devices (S-4000 RCS).

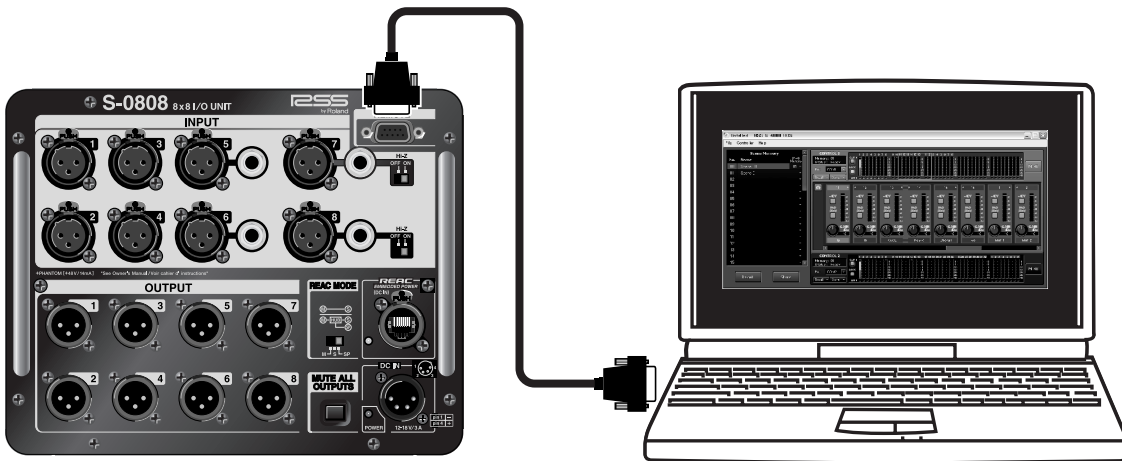

Download S-4000 RCS software and the user guide from the following Roland website.

<http://www.rolandsystemsgroup.net/>

* Refer to the User Guide of S-4000 RCS for details of operations and system requirements.

Making settings using S-4000 RCS offers the following advantages.

- You can view a list of the input levels on all channels.
- You can set and view a list of parameters (phantom power, pad, etc.) on all channels.
- You can save and recall up to 100 settings.
- If your computer has multiple RS-232C ports, you can control more than one system (up to four).

Making Settings Using the RSS V-Mixer

You can also make the settings for input channels at the panel on the RSS V-Mixer. Connect the RSS V-Mixer to the S-0808, then make various settings at the CHANNEL DISPLAY screen.

* Depending on the version of the RSS V-Mixer, the S-0808 units might be recognized as S-4000S units (each made up of 8 input and 8 output modules).



Troubleshooting

Power Supply

No power is supplied by REAC EMBEDDED POWER.

Does the connected device supply REAC EMBEDDED POWER? Is the REAC connection cable free of broken wires or other problems?

To receive REAC EMBEDDED POWER, an S-4000M, S-4000D, or other source device of REAC EMBEDDED POWER must be connected. For information on cables for REAC connections, refer to “Before Making REAC Connections” (p. 13).

The S-0808 may not boot up correctly if the power supply from your REAC EMBEDDED POWER device is started while S-4000R is connected to S-0808’s REMOTE connector. Disconnect the S-4000R and start power from your REAC EMBEDDED POWER device first. Check that S-0808 is booted correctly and then connect the S-4000R.

No power is supplied by the external battery.

Is the battery compatible with the rated voltage of the S-0808?

When receiving power from an external battery, the voltage must be between 12 V and 18 V. Check the output voltage of the battery. Also, batteries for broadcast video-cameras have a feature to display the remaining charge. Check the remaining charge before connecting.

Input and Output

No input or output is possible.

Is the operation mode set correctly?

REAC has the following three operation modes, and the mode setting for each connected REAC device must be made correctly. Making the wrong settings may result in incorrect audio input and output.

- M The unit functions as a REAC master device.
- S The unit functions as a REAC slave device.
- SP The unit functions as a REAC split device.

For information about the various connection methods and their corresponding operation-mode settings, refer to “Connecting REAC Devices”(p. 13).

The volume of the instrument connected to INPUT 1 - 8 is too low.

Could you be using a connection cable that contains a resistor ? Use a connection cable that does not contain any resistor.

The output level is too high.

Does the nominal input level of the output-destination device (amp, speaker, deck, or the like) match the output level of the S-0808?

The output level of the S-0808 is +4 dBu (nominal, maximum: +22 dBu). If the output level is too high even when the input gain has been turned down on the output-destination device, interpose an attenuator between the output-destination device and the S-0808. Adjustment can also be made by lowering the preamp gain on the S-0808, but this may result in a poor signal-to-noise ratio.

Channel Settings

The input channel cannot be set using the S-4000R.

Is an external battery connected to the S-0808? Also, does the connected external battery have enough charge remaining?

Even when power is received from a device providing REAC EMBEDDED POWER, if S-0808 is supplying +48 V phantom power to input devices, an external battery is necessary for the S-0808 to supply power to the S-4000R.

Noise occurs when the preamp gain is adjusted.

When you set the preamp gain using the S-4000R or S-4000 RCS, a slight amount of noise may occur when switching between the values shown below, but this is not a malfunction.

- PAD on: At three locations: +3 and +2, -13 and -14, or -29 and -30 (dBu)
- PAD off: At three locations: +17 and -18, -33 and -34, or -49 and -50 (dBu)

Also, changes in preamp gain may sometimes not feel smooth, but this also is not a malfunction.

The channel setting cannot be saved on the S-4000R.

When the S-0808 is connected, the S-4000R's MEMORY buttons (STORE/RECALL) do not function. If you want to save multiple settings, download and use S-4000 RCS dedicated remote control software, which is available at the following Roland website.
<http://www.rolandsystemsgroup.net/>

Other Matters

An M-48 connected via an S-4000D cannot be controlled.

You can connect an M-48 live personal mixer to the S-0808 via an S-4000D, but remote control of the M-48 using dedicated software on a computer connected to the REMOTE connector on the S-0808 is not possible. For more information about configuring a system that includes the M-48, refer to "Connecting Via an S-4000D (Configuring an M-48 System)" (p. 18).

Main Specifications

PROCESSING		CONNECTORS	
Number of Channels	8 in / 8 out	REAC	RJ-45, Ethernet type x 1
AD/DA Conversion	Sampling Frequency : 96kHz, 48kHz, 44.1kHz Signal Processing : 24 bit	DC IN	XLR 4 pin type x 1 (DC 12V - 18V)
INPUT / OUTPUT CHARACTERISTICS		REMOTE	RS-232C (D-Sub 9 pin type) x 1
Frequency Response	-2dB / +0dB (@+4dBu, 20Hz - 20kHz)	Analog Input (Balanced, Phantom Power)	INPUT 1 - 8 : XLR 3 pin type x 8 INPUT 5 - 8 : TRS standard type x 4 * TRS takes priority if XLR and TRS are simultaneously input to 5-8. * INPUT 7/8 with Hi-Z switch (unbalanced when Hi-Z is turned on)
Total Harmonic Distortion + Noise	0.04% or less (PAD:On, Input Gain:+4dBu, typ.)	Analog Output	XLR 3 pin type x 8 (Balanced)
Dynamic Range	110dB	OTHERS	
Cross Talk	-80dB or less (Input Gain:+4dBu, typ.)	Network Latency	375 microseconds (AD - REAC - DA latency : about 1.2ms)
Nominal Input Level	-65 to -10dBu (PAD : Off) -45 to +10dBu (PAD : On) (1dB step, Max +28dBu)	Power Supply	REAC EMBEDDED POWER or External Battery (DC 12V - 18V)
Nominal Output Level	+4dBu (Max +22dBu)	Power Consumption	26W (at DC 12V)
PAD	20dB On/Off	Phantom Power	+48V / Max14mA (INPUT 1 - 8)
Input Impedance	7k ohms	Operation Temperature	0 to +40 degrees Celsius, +32 to +104 degrees Fahrenheit
Recommended Load Impedance	10k ohms or greater	Dimensions/Weight	220(W) x 176(D) x 156.6(H) mm, 2.9 kg 8-11/16(W) x 6-15/16(D) x 6-3/16(H) inches, 6 lbs 7oz
Residual Noise Level (IHF-A, typ.)	-80dBu or less	Accessories	Battery Plate Holder and Fastening Screws (8 pcs), REAC Connector Cover, Ferrite Core (2 pcs), Bottom Panel Fastening Screws (4 pcs), Owner's Manual
Equivalent Input Noise Level (E.I.N.)	-128dB		

* 0dBu = 0.775Vms

* In the interest of product improvement, the specifications and/or appearance of this unit are subject to change without prior notice.

* When a REAC Splitter or a switching hub is used in-line with REAC cables, the network latency will increase the amount of processing delay introduced by the splitting device itself. The actual delay is dependant upon the specifications of the splitting device, though the maximum delay amount for a single splitting device should be around 200 microseconds.

Operating Time with Battery

IDX ENDURA-7	IDX ENDURA-10
Approx 3.5 hours	Approx 4.5 hours

* This is the operating time when +48 V phantom power is supplied from all INPUT channels.

* Operating times may vary depending on ambient temperature, the current consumption of the device receiving +48 V phantom power, and other usage conditions.

* If the battery charge runs out and S-0808's power source is switched to REAC EMBEDDED POWER, output audio might be muted for few seconds.

Connector Information

REAC Connector

Cat5e Crossover Wiring

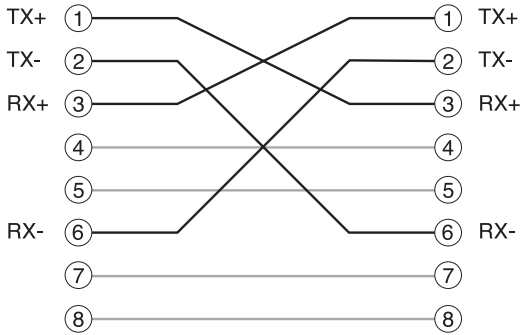

Cat5e Straight Wiring

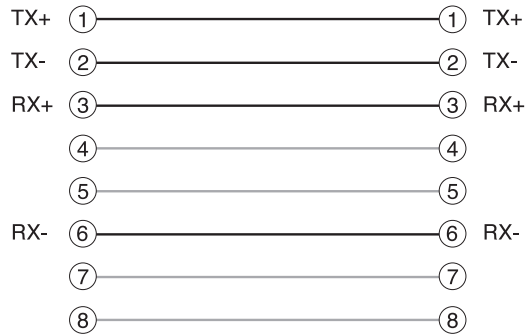

REMOTE Connector

* Cable length should be 15 meters or shorter.

Pin No.	Signal
1	NC
2	TxD(Data Out)
3	RxD(Data In)
4	NC
5	GND
6	+5V
7	Short to Pin 8
8	Short to Pin 7
9	NC

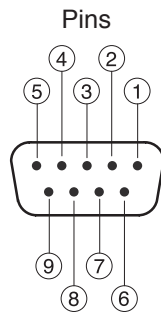

Included RS-232C cable

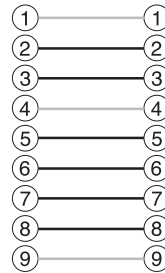

INPUT/OUTPUT Connector

* Connect COLD and GND when connecting XLR unbalanced.

XLR Balanced

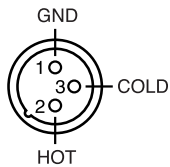

XLR Unbalanced

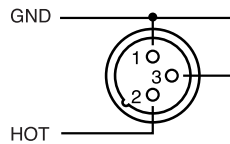

TRS Balanced



DC IN connector

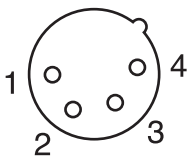

- 1 : - (minus)
- 2 : NC
- 3 : NC
- 4 : + (plus)

Dimensions

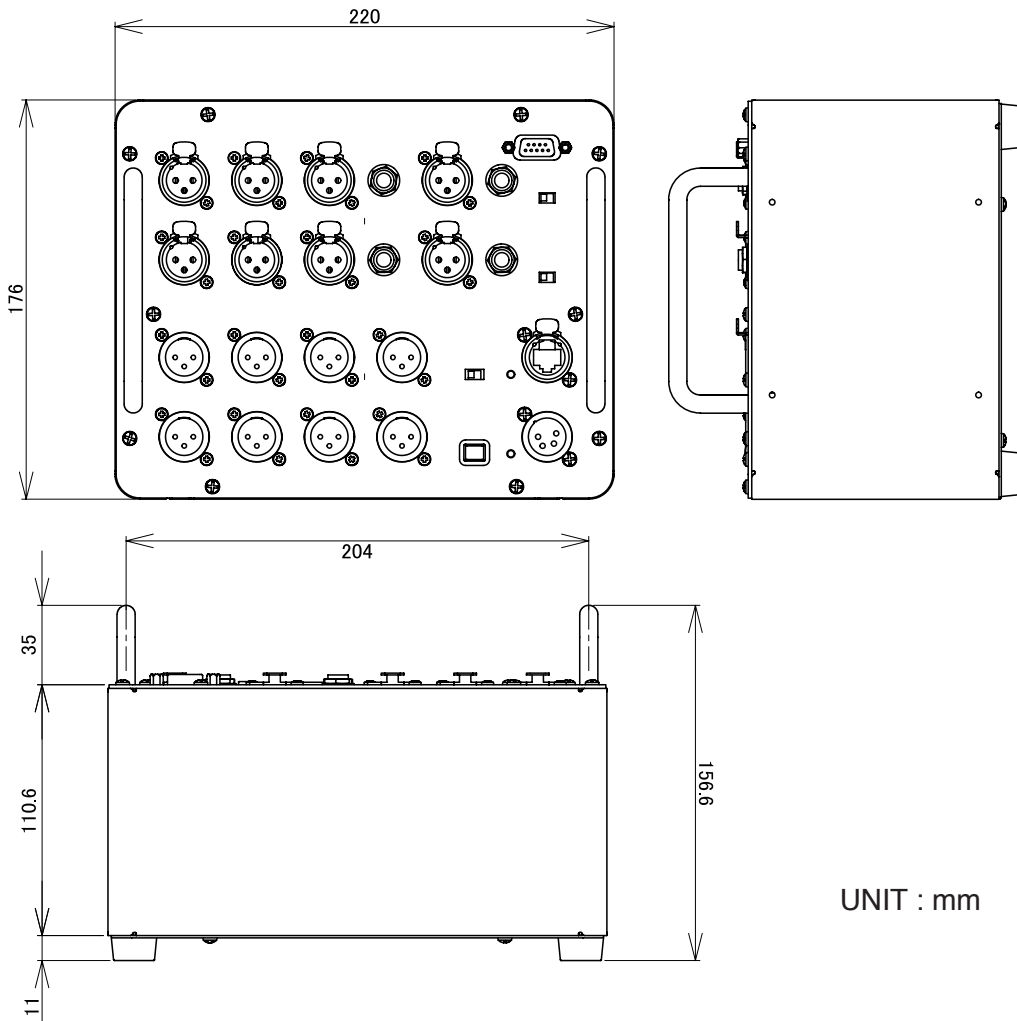

UNIT : mm

* If you find loose fasteners on the carrying handles, immediately stop usage of the unit and contact the nearest Roland Service Center, or authorized Roland distributor, as listed on the "Information" page.

Memo



For EU Countries

This product complies with the requirements of EMC Directive 2004/108/EC.

For the USA

FEDERAL COMMUNICATIONS COMMISSION RADIO FREQUENCY INTERFERENCE STATEMENT

This equipment has been tested and found to comply with the limits for a Class B digital device, pursuant to Part 15 of the FCC Rules. These limits are designed to provide reasonable protection against harmful interference in a residential installation. This equipment generates, uses, and can radiate radio frequency energy and, if not installed and used in accordance with the instructions, may cause harmful interference to radio communications. However, there is no guarantee that interference will not occur in a particular installation. If this equipment does cause harmful interference to radio or television reception, which can be determined by turning the equipment off and on, the user is encouraged to try to correct the interference by one or more of the following measures:

- Reorient or relocate the receiving antenna.
- Increase the separation between the equipment and receiver.
- Connect the equipment into an outlet on a circuit different from that to which the receiver is connected.
- Consult the dealer or an experienced radio/TV technician for help.

This device complies with Part 15 of the FCC Rules. Operation is subject to the following two conditions:

- (1) this device may not cause harmful interference, and
- (2) this device must accept any interference received, including interference that may cause undesired operation.

Unauthorized changes or modification to this system can void the users authority to operate this equipment. This equipment requires shielded interface cables in order to meet FCC class B Limit.

For Canada

NOTICE

This Class B digital apparatus meets all requirements of the Canadian Interference-Causing Equipment Regulations.

AVIS

Cet appareil numérique de la classe B respecte toutes les exigences du Règlement sur le matériel brouilleur du Canada.

For C.A. US (Proposition 65)

WARNING

This product contains chemicals known to cause cancer, birth defects and other reproductive harm, including lead.

For China

有关产品中所含有害物质的说明

本资料就本公司产品中所含的特定有害物质及其安全性予以说明。

本资料适用于 2007 年 3 月 1 日以后本公司所制造的产品。

环保使用期限



此标志适用于在中国国内销售的电子信息产品，表示环保使用期限的年数。所谓环保使用期限是指在自制造日起的规定的期限内，产品中所含的有害物质不致引起环境污染，不会对人身、财产造成严重的不良影响。环保使用期限仅在遵照产品使用说明书，正确使用产品的条件下才有效。不当的使用，将会导致有害物质泄漏的危险。

产品中有毒有害物质或元素的名称及含量

部件名称	有毒有害物质或元素					
	铅(Pb)	汞(Hg)	镉(Cd)	六价铬(Cr(VI))	多溴联苯(PBB)	多溴二苯醚(PBDE)
外壳(壳体)	×	○	○	○	○	○
电子部件(印刷电路板等)	×	○	×	○	○	○
附件(电源线、交流适配器等)	×	○	○	○	○	○

○：表示该有毒有害物质在该部件所有均质材料中的含量均在 SJ/T11363-2006 标准规定的限量要求以下。

×：表示该有毒有害物质至少在该部件的某一均质材料中的含量超出 SJ/T11363-2006 标准规定的限量要求。

因根据现有的技术水平，还没有什么物质能够代替它。

For EU Countries



- UK** This symbol indicates that in EU countries, this product must be collected separately from household waste, as defined in each region. Products bearing this symbol must not be discarded together with household waste.
- DE** Dieses Symbol bedeutet, dass dieses Produkt in EU-Ländern getrennt vom Hausmüll gesammelt werden muss gemäß den regionalen Bestimmungen. Mit diesem Symbol gekennzeichnete Produkte dürfen nicht zusammen mit dem Hausmüll entsorgt werden.
- FR** Ce symbole indique que dans les pays de l'Union européenne, ce produit doit être collecté séparément des ordures ménagères selon les directives en vigueur dans chacun de ces pays. Les produits portant ce symbole ne doivent pas être mis au rebut avec les ordures ménagères.
- IT** Questo simbolo indica che nei paesi della Comunità europea questo prodotto deve essere smaltito separatamente dai normali rifiuti domestici, secondo la legislazione in vigore in ciascun paese. I prodotti che riportano questo simbolo non devono essere smaltiti insieme ai rifiuti domestici.
Ai sensi dell'art. 13 del D.Lgs. 25 luglio 2005 n. 151.
- ES** Este símbolo indica que en los países de la Unión Europea este producto debe recogerse aparte de los residuos domésticos, tal como esté regulado en cada zona. Los productos con este símbolo no se deben depositar con los residuos domésticos.
- PT** Este símbolo indica que nos países da UE, a recolha deste produto deverá ser feita separadamente do lixo doméstico, de acordo com os regulamentos de cada região. Os produtos que apresentem este símbolo não deverão ser eliminados juntamente com o lixo doméstico.
- NL** Dit symbool geeft aan dat in landen van de EU dit product gescheiden van huishoudelijk afval moet worden aangeboden, zoals bepaald per gemeente of regio. Producten die van dit symbool zijn voorzien, mogen niet samen met huishoudelijk afval worden verwijderd.
- DK** Dette symbol angiver, at i EU-lande skal dette produkt opsamles adskilt fra husholdningsaffald, som defineret i hver enkelt region. Produkter med dette symbol må ikke smides ud sammen med husholdningsaffald.
- NO** Dette symbolet indikerer at produktet må behandles som spesialavfall i EU-land, iht. til retningslinjer for den enkelte regionen, og ikke kastes sammen med vanlig husholdningsavfall. Produkter som er merket med dette symbolet, må ikke kastes sammen med vanlig husholdningsavfall.
- SE** Symbolen anger att i EU-länder måste den här produkten kasseras separat från hushållsavfall, i enlighet med varje regions bestämmelser. Produkter med den här symbolen får inte kasseras tillsammans med hushållsavfall.
- FI** Tämä merkintä ilmaisee, että tuote on EU-maissa kerättävä erillään kotitalousjätteistä kunkin alueen voimassa olevien määräysten mukaisesti. Tällä merkinnällä varustettuja tuotteita ei saa hävittää kotitalousjätteiden mukana.
- HU** Ez a szimbólum azt jelenti, hogy az Európai Unióban ezt a terméket a háztartási hulladéktól elkülönítve, az adott régióban érvényes szabályozás szerint kell gyűjteni. Az ezzel a szimbóllummal ellátott termékeket nem szabad a háztartási hulladék közé dobni.
- PL** Symbol oznacza, że zgodnie z regulacjami w odpowiednim regionie, w krajach UE produktu nie należy wyrzucać z odpadami domowymi. Produktów opatrzonych tym symbolem nie można utylizować razem z odpadami domowymi.
- CZ** Tento symbol udává, že v zemích EU musí být tento výrobek sbírán odděleně od domácího odpadu, jak je určeno pro každý region. Výrobky nesoucí tento symbol se nesmí vyhazovat spolu s domácím odpadem.
- SK** Tento symbol vyjadruje, že v krajinách EÚ sa musí zber tohto produktu vykonávať oddelene od domového odpadu, podľa nariadení platných v konkrétnej krajine. Produkty s týmto symbolom sa nesmú vyhazovať spolu s domovým odpadom.
- EE** See sümbol näitab, et EL-i maades tuleb see toode olemprügist eraldi koguda, nii nagu on igas piirkonnas määratletud. Selle sümboliga märgitud tooteid ei tohi ära visata koos olmeprügiga.
- LT** Šis simbolis rodo, kad ES šalyse šis produktas turi būti surenkamas atskirai nuo buitinių atliekų, kaip nustatyta kiekviename regione. Šiuo simboliu paženklinėti produktai neturi būti išmetami kartu su buitinėmis atliekomis.
- LV** Šis simbols norāda, ka ES valstīs šo produktu jāievāc atsevišķi no mājsaimniecības atkritumiem, kā noteikts katrā reģionā. Produktus ar šo simbolu nedrīkst izmest kopā ar mājsaimniecības atkritumiem.
- SI** Ta simbol označuje, da je treba proizvod v državah EU zbirati ločeno od gospodinjskih odpadkov, tako kot je določeno v vsaki regiji. Proizvoda s tem znakom ni dovoljeno odlagati skupaj z gospodinjskimi odpadki.
- GR** Το σύμβολο αυτό υποδηλώνει ότι στις χώρες της Ε.Ε. το συγκεκριμένο προϊόν πρέπει να συλλέγεται χωριστά από τα υπόλοιπα οικιακά απορρίμματα, σύμφωνα με όσα προβλέπονται σε κάθε περιοχή. Τα προϊόντα που φέρουν το συγκεκριμένο σύμβολο δεν πρέπει να απορρίπτονται μαζί με τα οικιακά απορρίμματα.

Information

When you need repair service, call your nearest Roland Service Center or authorized Roland distributor in your country as shown below.

ASIA

INDONESIA

PT. Citra IntiRama
Jl. Cideng Timur No. 15J-15O
Jakarta Pusat
INDONESIA
TEL: (021) 632-4170

CHINA

Roland Shanghai Electronics Co.,Ltd.
5F. No.1500 Pingliang Road
Shanghai 200090, CHINA
TEL: (021) 5580-0800

Roland Shanghai Electronics Co.,Ltd.
(BEIJING OFFICE)
10F. No.18 3 Section Anhuaxili
Chaoyang District Beijing
100011 CHINA
TEL: (010) 6426-5050

KOREA

KOREA AVICS CO., LTD.
Unit B-2208, Woolimblue9,
#240-21, Yeomchang-dong,
Gangseo-gu, Seoul, Korea
Tel: 02-322-3264

TAIWAN

ROLAND TAIWAN
ENTERPRISE CO., LTD.
Room 5, 9fl. No. 112 Chung Shan
N.Road Sec.2, Taipei, TAIWAN,
R.O.C.
TEL: (02) 2561 3339

SINGAPORE/ MALAYSIA

Roland Asia Pacific Sdn.
Bhd.
45-1, Block C2, Jalan PJU 1/39,
Dataran Prima, 47301 Petaling
Jaya, Selangor, MALAYSIA
TEL: 3-7805-3263

CENTRAL/LATIN AMERICA

BRAZIL

Roland Brasil Ltda.
Rua San Jose, 211
Parque Industrial San Jose
Cofia - Sao Paulo - SP, BRAZIL
TEL: (011) 4615 5666

Other CENTRAL/ LATIN AMERICA

Roland Systems Group U.S.
425 Sequoia Drive Suite 114,
Bellingham, Washington,
98226 USA
TEL: 360-594-4282

EUROPE

AUSTRIA/BELGIUM/ FRANCE/GERMANY/ HOLLAND/ LUXEMBOURG/ PORTUGAL/SPAIN/ SWITZERLAND

Roland Iberia, S.L.
Paseo Garca Faria, 33-35
08005 Barcelona SPAIN
TEL: 93 493 91 00

CROATIA

ART-CENTAR
Degenova 3,
HR - 10000 Zagreb
TEL: (1) 466 8493

CZECH REP.

CZECH REPUBLIC
DISTRIBUTOR s.r.o
Voctárova 247/16
CZ - 180 00 PRAHA 8,
CZECH REP.
TEL: (2) 830 20270

DENMARK

Roland Scandinavia A/S
Nordhavnsvej 7, Postbox 880,
DK-2100 Copenhagen
DENMARK
TEL: 3916 6200

FINLAND

Roland Scandinavia As,
Filial Finland
Elannontie 5
FIN-01510 Vantaa, FINLAND
TEL: (0)9 68 24 020

HUNGARY

Roland East Europe Ltd.
Warehouse Area 'DEPO' Pf.83
H-2046 Torokbalint, HUNGARY
TEL: (23) 511011

NORWAY

Roland Scandinavia Avd.
Kontor Norge
Lilleakerveien 2 Postboks 95
Lilleaker N-0216 Oslo
NORWAY
TEL: 2273 0074

POLAND

ROLAND POLSKA SP. Z O.O.
ul. Kty Grodziskie 16B
03-289 Warszawa, POLAND
TEL: (022) 678 9512

ROMANIA

FBS LINES
Piata Libertatii 1,
535500 Gheorgheni, ROMANIA
TEL: (266) 364 609

RUSSIA

MuTek
Dorozhnaya ul.3,korp.6
117 545 Moscow, RUSSIA
TEL: (095) 981-4967

SLOVAKIA

DAN Acoustic s.r.o.
Povazská 18.
SK - 940 01 Nové Zámky
TEL: (035) 6424 330

SWEDEN

Roland Scandinavia A/S
SWEDISH SALES OFFICE
Danvik Center 28, 2 tr.
S-131 30 Nacka SWEDEN
TEL: (0)8 702 00 20

UKRAINE

EURHYTHMICS Ltd.
P.O.Box: 37-a.
Nedecey Str. 30
UA - 89600 Mukachevo,
UKRAINE
TEL: (03131) 414-40

UNITED KINGDOM/ IRELAND

Roland (U.K.) Ltd.
Atlantic Close, Swansea
Enterprise Park, Swansea
SA7 9FJ,
UNITED KINGDOM
TEL: (01792) 702701

OCEANIA

AUSTRALIA/ NEW ZEALAND

Roland Corporation
Australia Pty.,Ltd.
38 Campbell Avenue
Dee Why West, NSW 2099
AUSTRALIA

For Australia
TEL: (02) 9982 8266
For New Zealand
TEL: (09) 3098 715

NORTH AMERICA

CANADA

Roland Canada Ltd.
(Head Office)
5480 Parkwood Way, Richmond
B. C., V6V 2M4 CANADA
TEL: (604) 270 6626

Roland Canada Ltd. (Toronto Office)

170 Admiral Boulevard
Mississauga ON L5T 2N6
CANADA
TEL: (905) 362 9707

U. S. A.

Roland Systems Group U.S.
425 Sequoia Drive Suite 114,
Bellingham, Washington,
98226 USA
TEL: 360-594-4282

As of Jan. 1, 2009 (RSS)



* 5 1 0 0 0 1 2 6 2 3 - 0 1 *